

EUROPE

5, Rue Henry Tudor L-5366 Munsbach Luxembourg
Tel: +352 263 507 73 15 EFax: +1 781 658 2511

UK

Preese Hall Farm, Weeton, PR43HT, UK
Tel: +44 1253 836 571 EFax: +1 781 658 2511

ITALY

Via Emilia Ovest, 56 int. 7-8 I-42048 Rubiera (RE), Italy
Tel: +39 0522 626307 Fax: +39 0522 260216

AFRICA

9 Midley road Jet Park, Boksburg Gauteng 1460, South Africa
Tel: +27 011 918-9501 EFax: +1 781 658 2511

MIDDLE EAST

Girne Mahallesi, Irmak Sokak Küçükyalı İş Merkezi A Blok No: 30
34852 Maltepe, Istanbul, Turkey
Tel: +90 531 221 87 60 EFax: +1 781 658 2511

ASIA

No. 553, Jhongshan Road Cingshuei, Taichung County Taiwan, 43643
Tel: +886 4 2622 3030 Fax: +886 4 2623 3300

CHINA

C208-C210 Zhongjiang Logistic Park, Xiazhuang Town
Chenyang District, Qingdao, Shandong, China 266107
Tel: +86-532-66888198,66888199 Fax: +86-532-66888193

INDIA

1st Floor, Room No. 205, World Trade Tower, Barakhamba Lane
Connaught Place, New Dehli 11000, India
Tel: +91 11 40509205, EFax: +1 781 658 2511

KOREA

#484-5, Hun Chang bldg 7F, Myeong Jang 1 Dong, Dong Rae Gu,
Busan, Korea
Tel: +82-51-526-7504 Fax: +82-51-527-7504

NORTH AMERICA

P.O. Box #782 300 Pond Street Randolph, MA 02368 U.S.A.
Tel: +1 781 607 2607 Fax: +1 781 658 2511

LATIN AMERICA

P.O. Box #2107-#2050 San Pedro, Costa Rica
Tel: +506 2253 8405 Fax: +1 781 658 2511

REGISTERED OFFICE

5th floor, 37 Esplanade, St. Helier-JE1 2TR, Jersey
The Channel Islands



globalwater solutions ltd.

World's Highest Quality
Pressure Tanks

E-mail: info@globalwatersolutions.com www.globalwatersolutions.com

EXCELLENCE
THROUGH

QUALITY

EXCELLENCE
THROUGH
QUALITY

Contents

- 01 GWS Introduction
- 03 Product Applications
- 04 Energy Saving Solutions

POTABLE WATER TANKS

- 05 PressureWave™
- 07 HydroGuard™
- 09 All-Weather™
- 11 M-Inox™
- 13 Max™ & UltraMax™
- 15 Challenger™
- 17 C2-Lite CAD™
- 19 FlowThru™
- 21 SuperFlow™
- 23 ThermoWave™

NON-POTABLE WATER TANKS

- 25 HeatWave™
- 27 SolarWave™

OTHER PRODUCTS/ACCESSORIES

- 29 PumpWave™
- 30 Accesories

GLOBAL WATER SOLUTIONS LTD. OFFERS A COMPREHENSIVE AND WIDE RANGE OF PRESSURE VESSELS

for heating, thermal, pressure booster, water hammer,
reverse osmosis and water well applications.

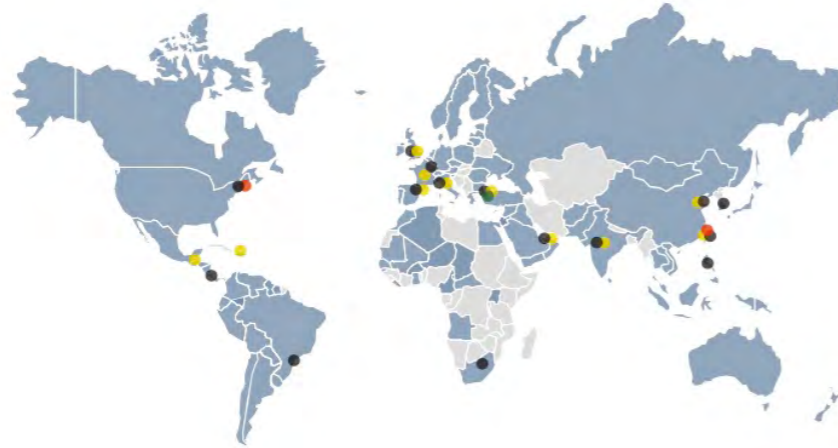

● Warehouses ● GWS Offices ● GWS Manufacturing Facilities ● Contract Manufacturing

GLOBAL WATER SOLUTIONS LTD. products are available in 100 countries worldwide covering Central and South America, Europe, The Middle East, Africa, Australia, New Zealand and Asia. GWS is a member of the Swan Group.

GLOBAL WATER SOLUTIONS LTD.'S

unique product offering includes both its patent protected CAD-2 diaphragm tanks as well as its line of single diaphragm tanks with a patented water connection and now also a series with replaceable tiered membrane design. This combination provides GLOBAL WATER SOLUTIONS LTD. customers with flexibility in selecting products for specific applications. All our products undergo a series of tests to insure the excellent quality. Beyond that, we offer our customers an extensive warranty.



GLOBAL WATER SOLUTIONS LTD. is also on the forefront of international regulatory issues with approvals from WRAS, NSF, PED, ACS, EVRAZES and other country specific approvals.



Product Applications

Our wide product range offers a full-line of pressure vessels for different applications. pressure vessels in sizes from 0.16-10,000 liters and in 10, 16 and 25 bar pressure ratings are available to accommodate all your requirements

- **PressureWave™, Challenger™, SuperFlow™ & C2Lite™, FlowThru™ Series**
Booster systems, water well systems, sprinklers, HVAC, thermal expansion, irrigation systems, water hammer arresting.
- **HeatWave™ Series**
Hydronic expansion, boiler systems.
- **SolarWave™ Series**
Closed loop solar systems, solar hot water expansion.
- **ThermoWave™ Series**
Potable Water Heating Applications.
- **RoWave™ Series**
Reverse Osmosis (RO) purified drinking water systems.
- **Ultra(Max)™ Series**
High pressure applications (16 and 25 bar).
- **M-Inox™ Series**
Stainless steel tanks ideally suited for special demands and environments.
- **HydroGuard™ Series**
Water hammer arresting, plumbing applications.



Energy Saving Solutions

Upsize your pressure tank and get the following benefits:

- Substantially reduce electric power consumption by reducing small draw off pump starts, i.e., evaporative coolers, toilet flushes, leaks, drip irrigation, etc.
- Extend pump life by dramatically reducing wear on moving parts
- Protect against heat expansion damage to pump bodies
- Reduce noise from unnecessary pump starts
- Eliminate motor burn outs and low flow cycling
- Eliminate pump body failures due to water hammer



Minimize your environmental footprint.



All this with a tank that...
 ... requires NO maintenance (does not require regular air charge checks) and
 ... has the longest warranty for guaranteed reliability.

PressureWave™ SERIES



FEATURES

- Single diaphragm design
- NSF Standard 61, CE/PED, WRAS, ACS, ISO:9001, Gost, Evrazes approved
- Patented stainless steel water connection
- Virgin polypropylene liner
- Two part polyurethane, epoxy primed paint finish
- Leak free, o-ring sealed air valve cap
- Comprehensive testing
- No maintenance

PressureWave™ tanks are ideally suited for a wide range of applications, including booster systems, thermal expansion, irrigation systems, and hydraulic hammer arresting.

The PressureWave™ Series is constructed of a virgin polypropylene liner combined with an FDA approved high grade butyl diaphragm. This is held against the wall of the tank with a steel clench ring. The brass air valve, sealed by a threaded o-ring valve cap, prevents air leaks. Water enters the tank through a patented stainless steel water connection. The diaphragm and liner are both reinforced in specific wear areas for longer life. All internal parts including the air valve are rounded to prevent piercing of the diaphragm in extreme conditions. The water connection uniquely provides a dual water/air seal ensuring a complete leak free and maintenance free pressure vessel.

On the exterior the almond colored two-part polyurethane paint finish over an epoxy undercoating provides hundreds of hours of UV and salt spray protection.

PressureWave™ tanks are quality tested at several stages on the production line to insure the structural integrity of every tank.

PressureWave™ tanks represent the best value for the investment and are the best quality pressure vessels available today.

SPECIFICATIONS

PressureWave™ Series Models

BSP	NPT	Nominal Volume		Shipping (box) Volume		Shipping (box) Weight		Dimensions					
		liter	gal	m ³	ft ³	kg	lbs	A		B		C	
								cm	inches	cm	inches	cm	inches
Inline Models													
PWB-2LX*	PWN-2LX*	2	0.5	0.06	2.12	13.60	29.98	20.90	8.23	12.60	4.96		
PWB-4LX	PWN-4LX	4	1.1	0.01	0.35	1.71	3.77	26.10	10.28	16.20	6.38		
PWB-8LX	PWN-8LX	8	2.1	0.014	0.49	2.40	5.29	31.30	12.32	20.20	7.95		
PWB-12LX	PWN-12LX	12	3.2	0.023	0.81	3.10	6.83	36.70	14.45	23.00	9.06		
PWB-18LX	PWN-18LX	18	4.8	0.03	1.06	4.10	9.04	36.70	14.45	27.90	10.98		
PWB-24LX	PWN-24LX	24	6.3	0.042	1.48	5.00	11.00	44.70	17.60	29.00	11.42		
PWB-35LX	PWN-35LX	35	9.3	0.056	1.98	7.00	15.43	48.10	18.90	31.80	12.52		
Horizontal Models													
PWB-8LH	PWN-8LH	8	2.1	0.013	0.46	2.46	5.42	31.30	12.32	23.20	9.13	11.60	4.57
PWB-12LH	PWN-12LH	12	3.2	0.024	0.85	3.25	7.17	36.70	14.45	26.00	10.24	13.00	5.12
PWB-20LH	PWN-20LH	20	5.3	0.04	1.41	5.00	11.02	44.70	17.60	29.40	11.57	14.70	5.79
PWB-24LH	PWN-24LH	24	6.3	0.047	1.65	5.90	13.01	44.70	17.60	32.10	12.64	16.10	6.34
PWB-35LH	PWN-35LH	35	9.3	0.061	2.15	8.20	18.08	48.10	18.94	35.30	13.90	17.90	7.05
PWB-60LH	PWN-60LH	60	15.9	0.09	3.18	11.40	25.13	53.00	20.87	42.40	16.69	21.50	8.46
PWB-80LH	PWN-80LH	80	21.1	0.13	4.59	16.10	35.49	72.60	28.58	42.40	16.69	21.50	8.46
PWB-100LH	PWN-100LH	100	26.4	0.16	5.65	19.20	42.33	72.00	28.35	47.50	18.70	24.50	9.65
Vertical Models w/ base													
PWB-35LV	PWN-35LV	35	9.3	0.063	2.22	7.80	17.20	55.50	21.85	31.80	12.52	12.00	4.72
PWB-60LV	PWN-60LV	60	15.9	0.098	3.46	11.80	26.01	62.00	24.41	38.90	15.31	12.70	5.00
PWB-80LV	PWN-80LV	80	21.1	0.13	4.59	16.20	35.71	81.50	32.09	38.90	15.31	12.70	5.00
PWB-100LV	PWN-100LV	100	26.4	0.16	5.65	19.10	42.11	80.40	31.65	43.00	16.93	12.90	5.08
PWB-130LV	PWN-130LV	130	34.3	0.21	7.42	26.70	58.86	107.40	42.28	43.00	16.93	12.90	5.08
PWB-150LV	PWN-150LV	150	40.0	0.28	9.89	31.4	69.23	92.40	36.38	53.00	20.87	13.85	5.45

* Minor dimensional variation may occur

Standard System Connection: 1"

All connections are stainless steel unless stated otherwise. Tank precharge: 1.9 bar / 28 psi
 Maximum Working Pressure: 10 bar / 150 psi Maximum Working Temperature: 90°C / 194°F
 Available in 16 and 25 bar as Max™ and UltraMax™ Series
 Available in smaller sizes as HydroGuard™ Series
 * PWB-2LX and PWN-2LX: 12 pcs/ box

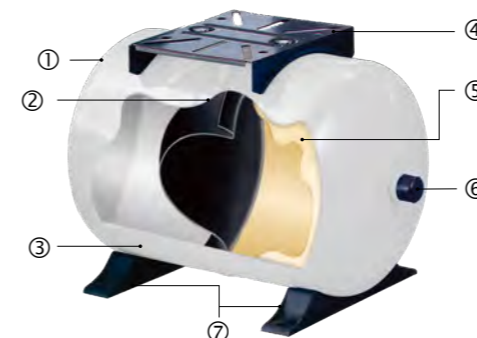

- ① Leak free, o-ring sealed air valve cap
- ② Single diaphragm design
- ③ Two part polyurethane, epoxy primed paint finish
- ④ Nylon Plastic Pump Stand
- ⑤ Virgin polypropylene liner
- ⑥ Patented stainless steel water connection
- ⑦ Plastic Tank Feet

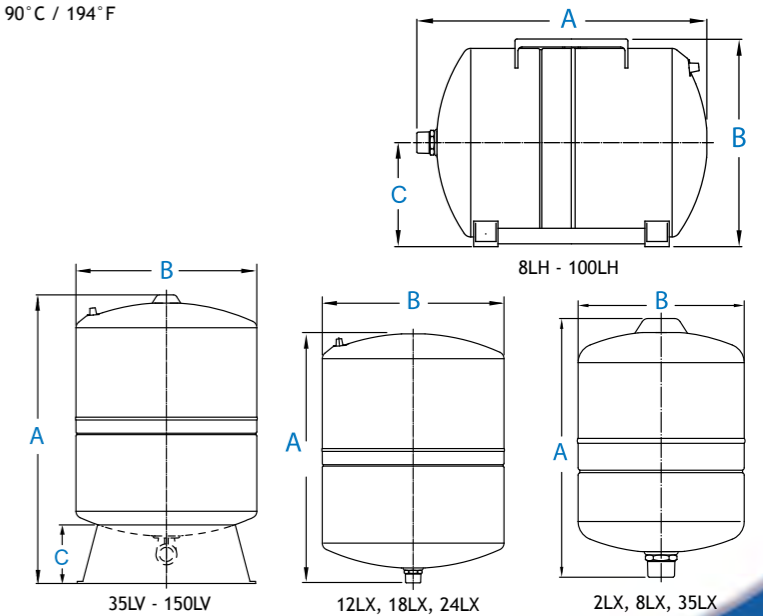

ISO:9001 CE ACS Approved



HydroGuard™ SERIES



FEATURES

- Single diaphragm design
- Patented stainless steel or Noryl water connection
- Two part polyurethane, epoxy primed paint finish
- Leak free, o-ring sealed air valve cap
- Comprehensive testing
- No maintenance

HydroGuard™ shock arrestors are specially designed for use in hydraulic hammer arresting applications.

HydroGuard™ shock arrestors are built to reduce or eliminate hydraulic shock, otherwise known as water hammer. They do this by absorbing pressure surges within water or other fluids that are suddenly stopped or forced in other directions by fast closing valves. HydroGuard™ shock arrestors are best used at the point of shock and should be installed as close to the valve or piping where the shock originates from.

HydroGuard™ shock arrestors are designed with the latest diaphragm technology. A high grade chlorobutyl diaphragm is sealed inside the vessel creating a barrier between fluid and air chambers. The air chamber acts as a cushion which compresses when system pressure suddenly increases or surges as a result of hydraulic shock.

HydroGuard™ shock arrestors are quality tested at several stages along the production line in ensure the structural integrity of every tank.

HydroGuard™ shock arrestors represent the best value for the investment and are the best quality shock arrestors available today.

SPECIFICATIONS HydroGuard™ Series Models

NPT	BSP	Connection	Nominal Volume		Shipping (box) Volume		Pieces per box	Shipping (box) Weight		Dimensions			
			liter	gal	m ³	ft ³		kg	lbs	A		B	
										cm	inches	cm	inches
HGNSA-0.16LX	HGNSA-0.16LX	1/2" SS	0.16	0.04	0.05	1.67	24	10.00	22.05	10.10	3.98	8.50	3.40
HGBSC-0.3LX	HGBSC-0.3LX	1/2" Noryl	0.3	0.08	0.05	1.67	40	15.82	34.88	10.00	3.94	9.70	3.80
HGBSC-0.5LX	HGBSC-0.5LX	1/2" Noryl	0.5	0.13	0.06	1.97	24	14.50	33.60	13.50	5.31	11.30	4.45
HGBSD-0.6LX	HGBSD-0.6LX	1/2" Noryl	0.6	0.16	0.04	1.24	20	11.68	25.75	13.78	5.43	11.30	4.45
HGPSO-1LX	HGPSO-1LX	1/2" Nylon	1	0.26	0.05	1.67	15	11.77	25.95	14.35	5.65	13.60	5.35
HGPSR-1LX	HGPSR-1LX	1/2" SS	1	0.26	0.07	2.42	20	17.90	39.46	19.70	7.76	12.00	4.72
HGPSO-2LX	HGPSO-2LX	3/4" Nylon	2	0.5	0.07	2.42	12	15.87	34.99	16.30	6.42	17.00	6.69
HGBPA-2LX	HGNPA-2LX	1" BSP/NPT	2	0.5	0.06	1.97	12	13.62	30.03	20.80	8.19	12.60	5.00
HGBPA-4LX	HGNPA-4LX	1" BSP/NPT	4	1.1	0.01	0.28	1	1.71	3.77	26.10	10.28	16.20	6.40

*Variations available, ask your sales person
 Maximum Working Pressure: 10 bar / 150 psi
 Maximum Working Temperature: 90°C / 194°F

* Minor dimensional variation may occur

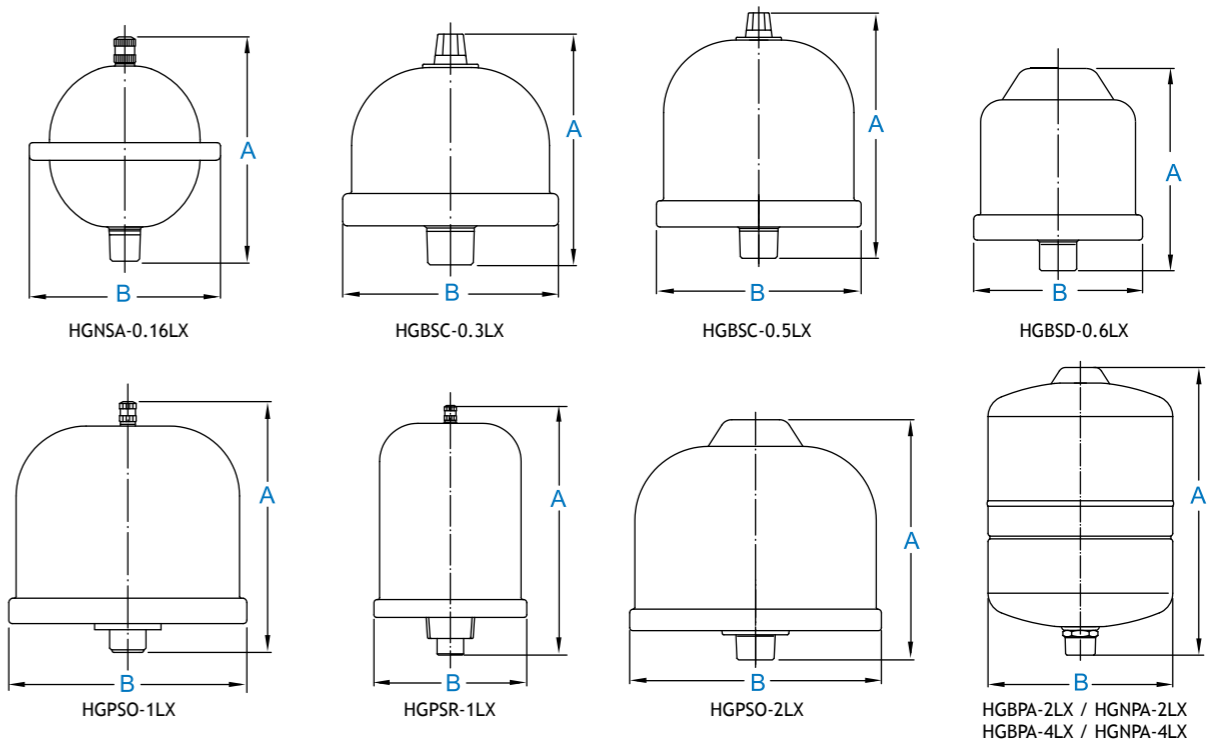

All-Weather™ SERIES



SPECIFICATIONS All-Weather™ Series Models

BSPT	NPT	Connection	Nominal Volume		Shipping (box) Volume		Shipping (box) Weight		Dimensions					
			liter	gal	m ³	ft ³	kg	lbs	A		B		C	
New Part Number	New Part Number	BSP / NPT							cm	inches	cm	inches	cm	inches
Inline														
AWB-18LX	AWN-18LX	1"	18	4.8	0.03	1.18	5.04	9.26	42.5	16.7	27.6	10.9	-	-
AWB-24LX	AWN-24LX	1"	24	6.3	0.04	1.52	5.35	11.97	45.4	17.9	30.1	11.9	-	-

Tank precharge: 1.9 bar / 28 psi
 Maximum Working Pressure: 10 bar / 150 psi
 Maximum Working Temperature: 90 °C / 194 °F

* Minor dimensional variation may occur

FEATURES

- Rugged Polypropylene outer shell
- 10 bar pressure rating
- Single diaphragm design
- Comprehensive testing
- Virgin Polypropylene liner
- Patented stainless steel water connection
- Leak free O-Ring sealed air valve
- Maintenance free

The GWS All-Weather Pressure Tank is constructed with a high grade steel tank encased in a rugged polypropylene outer shell. The patented PLASTEEL shell creates an impenetrable layer of protection that shields against the harshest of elements. Wind, rain, sleet or sun is no match for the All-Weather Pressure Tank, making it the perfect solution for marine and mining applications, as well as harsh environmental conditions. With the highest quality and all Major Global Approvals, the GWS All-Weather Pressure Tank represents the greatest innovation in pressure tank technology today.



- ① Polypropylene shell
- ② Internal steel dome
- ③ Virgin polypropylene liner
- ④ High grade butyl diaphragm
- ⑤ Patented stainless steel water connection

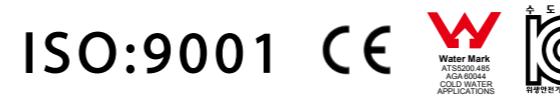
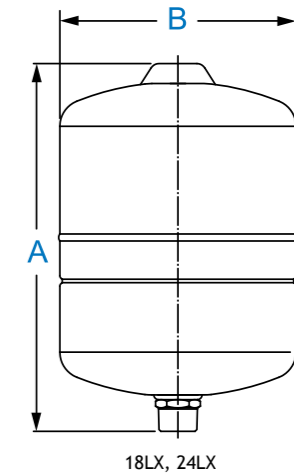

M-Inox™ SERIES



FEATURES

- High Grade Stainless Steel Tank construction
- Single diaphragm design
- NSF Standard 61, CE/PED, WRAS, ACS, ISO:9001, Gost, Evrazes approved
- Patented stainless steel water connection
- Virgin polypropylene liner
- Leak free, o-ring sealed air valve cap
- Comprehensive testing
- No maintenance

M-Inox™ stainless steel tanks are ideally suited for special demands and environments.

The M-Inox™ Series is constructed of a virgin polypropylene liner combined with an FDA approved high grade butyl diaphragm. This is held against the wall of the tank with a steel clench ring. The brass air valve, sealed by a threaded o-ring valve cap, prevents air leaks. Water enters the tank through a patented stainless steel water connection. The diaphragm and liner are both reinforced in specific wear areas for longer life. All internal parts including the air valve are rounded to prevent piercing of the diaphragm in extreme conditions. The water connection uniquely provides a dual water/air seal ensuring a complete leak free and maintenance free pressure vessel.

M-Inox™ tanks are quality tested at several stages on the production line to insure the structural integrity of every tank.

M-Inox™ tanks represent the best value for the investment and are the best quality stainless steel pressure vessels available today.

SPECIFICATIONS M-Inox™ Series Models

BSP	NPT	Connec-tion	Nominal Volume		Shipping (box) Volume		Shipping (box) Weight		Dimensions					
			liter	gal	m ³	ft ³	kg	lbs	A		B		C	
		BSP / NPT							cm	inches	cm	inches	cm	inches
MIB-8LX	MIN-8LX	1"	8	2.1	0.014	0.49	2.35	5.18	31.30	12.32	20.20	7.95		
MIB-18LX	MIN-18LX	1"	18	4.8	0.03	1.06	4.11	9.06	38.40	15.12	27.90	11.20		
MIB-24LX	MIN-24LX	1"	24	6.3	0.042	1.48	4.70	10.36	29.00	11.42	44.7	17.60		
MIB-18LH	MIN-18LH	1"	18	4.8	0.048	1.70	4.82	10.63	38.40	15.12	30.90	12.17	15.50	6.10

Tank precharge: 1.9 bar / 28 psi

Maximum Working Pressure: 10 bar / 150 psi Maximum Working Temperature: 90°C / 194°F

* Minor dimensional variation may occur

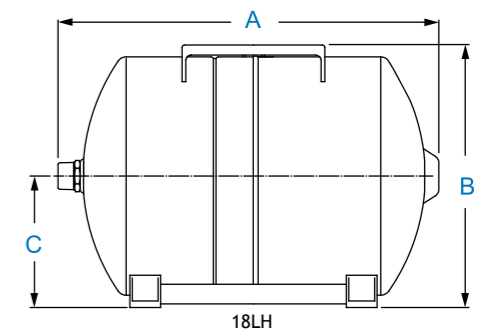
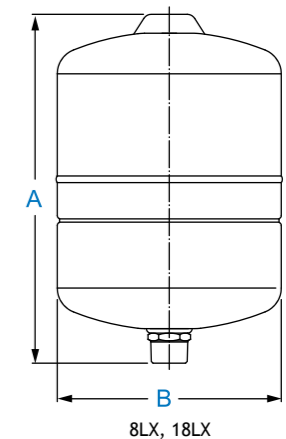

- ① Stainless Steel Tank
- ② Water Chamber
- ③ Patented Stainless Steel Water Connection
- ④ Leak-Free O-ring Sealed Air Valve Cap
- ⑤ High Grade Butyl Diaphragm
- ⑥ Virgin Polypropylene Liner

ISO:9001 CE ACS Approved



Max™ & UltraMax™ SERIES



SPECIFICATIONS Max™ Series Models (16 bar)

BSP	NPT	Connec- tion	Nominal Volume		Shipping (box) Volume		Shipping (box) Weight		Dimensions					
			liter	gal	m³	ft³	kg	lbs	A		B		C	
		BSP / NPT							cm	inches	cm	inches	cm	inches
MXB-2LX*	MXN-2LX*	1"	2	0.5	0.06	2.12	0.80	1.76	20.90	8.23	12.60	4.96		
MXB-8LX	MXN-8LX	1"	8	2.1	0.014	0.49	2.43	5.36	31.30	12.32	20.20	7.95		
MXB-12LX	MXN-12LX	1"	12	3.2	0.023	0.81	3.20	7.05	33.70	14.37	23.00	9.06		
MXB-18LX	MXN-18LX	1"	18	4.7	0.03	1.06	4.76	10.49	36.70	14.45	27.90	10.98		
MXB-24LX	MXN-24LX	1"	24	6.3	0.042	1.48	5.95	13.12	44.70	17.60	29.00	11.42		
MXB-35LX	MXN-35LX	1"	35	9.2	0.06	1.95	8.57	18.89	48.10	18.90	31.80	12.52		
MXB-60LV	MXN-60LV	1"	60	15.8	0.098	3.46	15.1	33.33	62.00	24.41	39.00	15.35	12.70	5.00
MXB-80LV	MXN-80LV	1"	80	21.0	0.13	4.59	20.7	45.61	81.50	32.09	39.00	15.35	12.70	5.00
MXB-100LV	MXN-100LV	1"	100	26.3	0.16	5.65	22.2	48.92	80.40	31.65	43.10	16.97	12.90	5.08

* Volume and weight for MXB-2LX and MXN-2LX mentioned for a box with 12 pieces. * Minor dimensional variation may occur
 All connections are made of stainless steel. Tank precharge: 4.0 bar / 58 psi
 Maximum working pressure: 16 bar / 232 psi. Maximum working temperature: 90°C / 194°F

FEATURES

- Suitable for many high-pressure applications
- Super thick steel construction
- Patented stainless steel water connection
- Virgin polypropylene liner
- Two part polyurethane, epoxy primed paint finish
- Leak free, o-ring sealed air valve cap
- Comprehensive testing
- No maintenance
- Single diaphragm design
- Available in 16 bar and 25 bar maximum pressure

SPECIFICATIONS UltraMax™ Series Models (25 bar)

BSP	NPT	Connection	Nominal Volume		Shipping (box) Volume		Shipping (box) Weight		Dimensions					
			liter	gal	m³	ft³	kg	lbs	A		B		C	
									cm	inches	cm	inches	cm	inches
Inline Models														
UMB-8LX	UMN-8LX	1"	8	2.1	0.014	0.49	3.49	7.67	31.30	12.32	20.30	7.99	-	-
UMB-24LX	UMN-24LX	1"	24	6.3	0.042	1.48	8.74	19.27	44.70	17.60	29.30	11.54	-	-
Vertical Models w/ base														
UMB-100LV	UMN-100LV	1"	100	26.3	0.16	5.69	39.9	87.96	82.3	32.40	43.5	17.13	12.9	5.08

All connections are made of stainless steel. Tank precharge: 4.0 bar / 58 psi * Minor dimensional variation may occur
 Maximum working pressure: 25 bar / 362 psi. Maximum working temperature: 90°C / 194°F

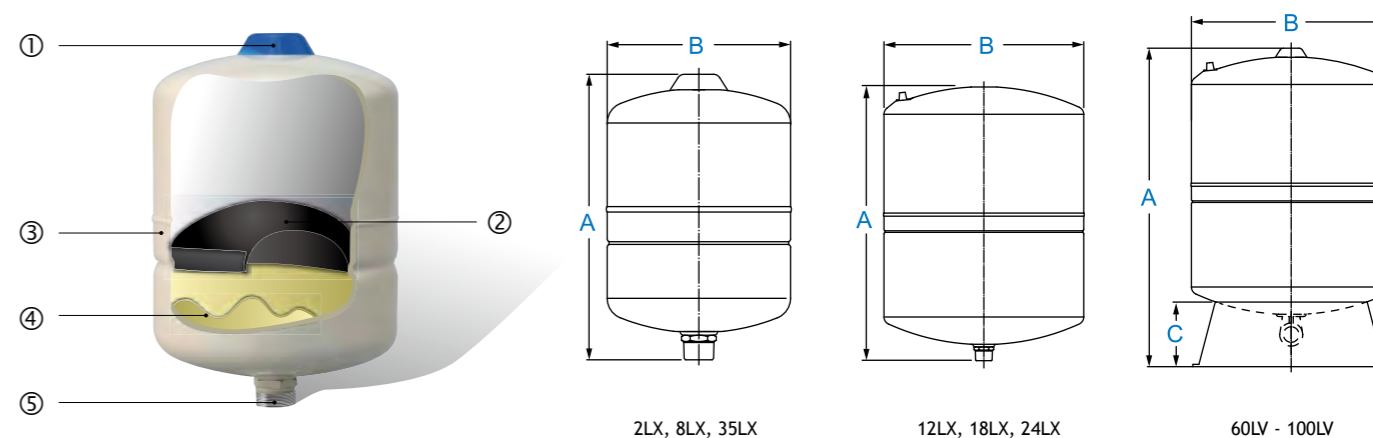

- ① Leak free, o-ring sealed air valve cap
- ② Single diaphragm design
- ③ Two part polyurethane, epoxy primed paint finish
- ④ Virgin polypropylene liner
- ⑤ Patented stainless steel water connection

ISO:9001 CE ACS Approved



Challenger™ SERIES



FEATURES

- Patented CAD-2 diaphragm technology
- NSF Standard 61, CE/PED, WRAS, ACS, ISO-9001, Gost, Evrazes approved
- Stainless steel water connection
- Condensation reducing design
- Two part polyurethane, epoxy primed paint finish
- Leak free air valve cap sealed with closed cell foam
- Comprehensive testing
- No maintenance

Challenger™ tanks are ideally suited for a wide range of applications, including booster systems, thermal expansion, heating expansion, irrigation systems, and hydraulic hammer arresting.

Water Chamber, Patented Controlled Action Design:
Efficient and cost effective, Challenger™ tanks are designed with a patented controlled action CAD-2 diaphragm assembly. It features a chlorine resistant 100% butyl diaphragm with a precision molded copolymer polypropylene liner for superior air and water separation. The CAD-2 diaphragm assembly is clenched together with a positive lock internal clench ring which contains drawdown water in a pre-charged air atmosphere, thus providing separation between the diaphragm and tank wall. This “air buffer” design means few problems with condensation. Constructed with an FDA approved high grade butyl, the diaphragm assembly seals water in a true non-corrosive chamber.

On the exterior, the almond colored two part polyurethane paint finish over an epoxy undercoating provides hundreds of hours of UV and salt spray protection.

The air chamber is sealed with a fixed o-ring and closed cell foam and will provide many years of leak free and service free life. Challenger™ tanks are quality tested at several stages on the production line to insure the structural integrity of every tank. Challenger™ tanks are the best steel pressure vessels in the market today and represent the best value for the investment.

SPECIFICATIONS Challenger™ Series Models

BSP	NPT	Nominal Volume		Shipping (box) Volume		Shipping (box) Weight		Dimensions							
		liter	gal	m ³	ft ³	kg	lbs	A		B		C		D	
								cm	inches	cm	inches	cm	inches	cm	inches
GCB-60LV	GCN-15GV	60	15	0.10	3.65	12.25	27.0	56.52	22.25	40.68	16.02	4.71	1.85	36.22	14.26
GCB-80LV	GCN-20GV	80	20	0.13	4.74	15.20	33.5	74.54	29.35	40.68	16.02	4.71	1.85	36.22	14.26
GCB-100LV	GCN-25GV	100	25	0.16	5.68	19.52	43.0	88.83	34.97	40.68	16.02	4.71	1.85	36.22	14.26
GCB-130LV	GCN-35GV	130	35	0.20	7.08	24.74	54.5	110.09	43.34	40.68	16.02	4.71	1.85	36.22	14.26
GCB-200LV	GCN-50GV	200	50	0.31	10.88	38.10	84.0	104.14	41.00	53.42	21.03	5.70	2.24	44.63	17.57
GCB-250LV	GCN-60GV	240	60	0.37	13.18	43.81	96.5	122.37	48.18	53.42	21.03	5.70	2.24	44.63	17.57
GCB-300LV	GCN-80GV	310	80	0.46	16.25	52.89	116.5	151.07	59.48	53.41	21.03	5.70	2.24	44.63	17.57
GCB-450LV	GCN-120GV	450	120	0.74	26.14	80.81	178.0	153.90	60.59	66.06	26.01	5.70	2.24	54.23	21.35

System Connection:

- Models GCB-60LV - GCB-130LV: 1" BSP stainless steel elbow
- Models GCB-200LV - GCB-450LV: 1 1/4" BSP stainless steel elbow
- Models GCN-15GV - GCN-35GV: 1" NPT stainless steel elbow
- Models GCN-50GV - GCN-120GV: 1 1/4" NPT stainless steel elbow

* Minor dimensional variation may occur
Please refer to tank packaging for correct factory set pre-charge information.

Maximum working temperature 90°C / 194°F
Maximum working pressure 10 bar / 150 psi

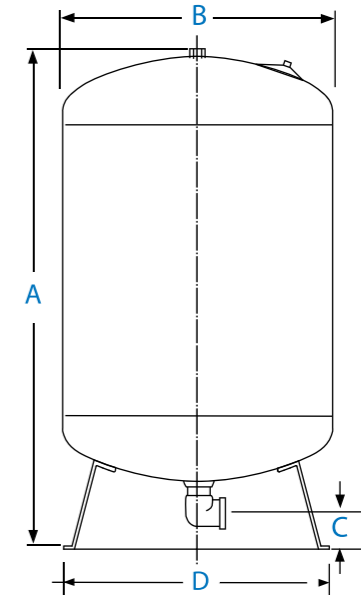

- ① Leak-Free, O-ring sealed air valve cap
- ② Two-part polyurethane / epoxy primed paint finish
- ③ Patented CAD-2 diaphragm design
- ④ Stainless steel water connection
- ⑤ Condensation reducing design
- ⑥ Virgin Polypropylene Liner

ISO:9001 CE ACS Approved



C2 Lite CAD™ SERIES



FEATURES

- Patented CAD-2 diaphragm technology
- Unique 3 piece construction
- Reinforced Plastic Connection
- Durable continuous strand fiberglass sealed with epoxy resin
- NSF Standard 61, CE/PED, WRAS, ACS, ISO:9001, Evrazes approved
- Rugged copolymer polypropylene base
- Quality brass air stem with o-ring seal
- No sweat design
- Comprehensive testing
- No maintenance

If you are looking for the proven performance of a GWS steel tank in a lightweight composite design, C2-Lite CAD™ series is the answer. Efficient and cost effective, C2-Lite CAD™ tanks are designed with the patented controlled action diaphragm design of GWS Challenger™ tanks. Unlike other composite tanks that hide tired old bag technology in a plastic shell, the patented CAD-2 diaphragm design is stronger and will not crease and wear out. It features a chlorine resistant 100% butyl diaphragm with a precision molded copolymer polypropylene liner for superior air and water separation. This patented design allows each size tank to have a properly sized water chamber matched to the drawdown performance of that tank. C2-Lite CAD™ tanks are easy to install, weather resistant and engineered to withstand even extreme environmental conditions. When it comes to performance and durability, the GWS C2-Lite CAD™ design cannot be beat.

C2-Lite CAD™ tanks are quality tested at several stages on the production line to insure the structural integrity of every tank. C2-Lite CAD™ tanks represent the best value for the investment and are the best quality composite vessels available today.

SPECIFICATIONS C2-Lite CAD™ Series Models

BSP	NTP	Nominal Volume		Shipping (box) Volume		Shipping (box) Weight		Dimensions							
		liter	gal	m ³	ft ³	kg	lbs	A		B		C		D	
								cm	inches	cm	inches	cm	inches	cm	inches
C2B-60LV	C2N-15GV	60	15	0.13	4.44	8.60	19.0	64.90	25.60	4.50	1.80	41.80	16.60	23.88	9.40
C2B-80LV	C2N-20GV	80	20	0.16	5.79	10.90	24.0	85.20	34.06	4.50	1.80	41.80	16.60	23.88	9.40
C2B-100LV	C2N-25GV	100	25	0.19	6.66	12.70	28.0	96.70	38.60	4.50	1.80	41.80	16.60	23.88	9.40
C2B-130LV	C2N-35GV	130	35	0.23	8.26	15.20	33.5	122.70	48.88	4.50	1.80	41.80	16.60	23.88	9.40
C2B-200LV	C2N-50GV	200	50	0.35	12.24	20.20	44.5	109.80	43.30	5.70	2.30	54.20	21.50	30.23	11.90
C2B-250LV	C2N-65GV	250	65	0.41	14.50	24.97	55.0	130.30	51.30	5.70	2.30	54.20	21.50	30.23	11.90
C2B-300LV	C2N-80GV	300	80	0.52	18.23	28.15	62.0	164.40	64.70	5.70	2.30	54.20	21.50	30.23	11.90
C2B-350LV	C2N-90GV	350	90	0.59	20.66	33.14	73.0	144.80	57.00	5.70	2.30	61.40	24.30	34.04	13.40
C2B-450LV	C2N-120GV	450	120	0.74	26.06	36.32	80.0	183.10	72.10	5.70	2.30	61.40	24.30	34.04	13.40

Max. Working Pressure 8.6 bar / 125 psi
 Max. Working Temperature 49°C / 120°F
 Connection C2B-60LV - C2B-130LV 1" BSP

C2B-200LV-C2B-450LV 1 1/4" BSP
 C2N-15GV - C2N-35GV 1" NPT C2N-50GV - C2N-120GV 1 1/4" NPT
 Please refer to tank packaging for correct factory set pre-charge information.

* Minor dimensional variation may occur

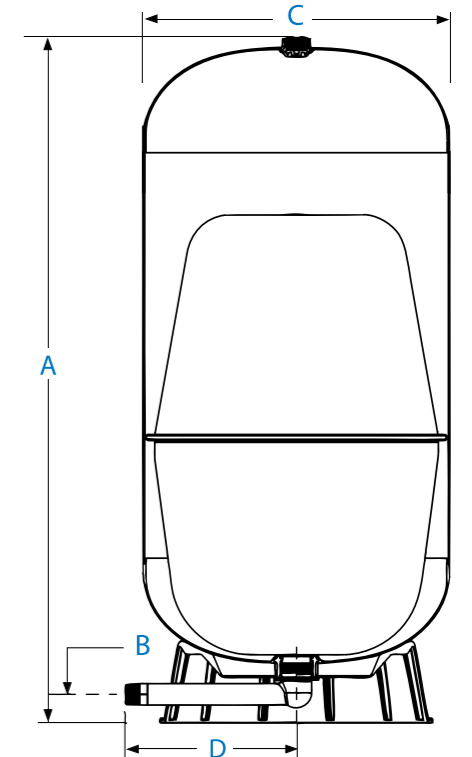
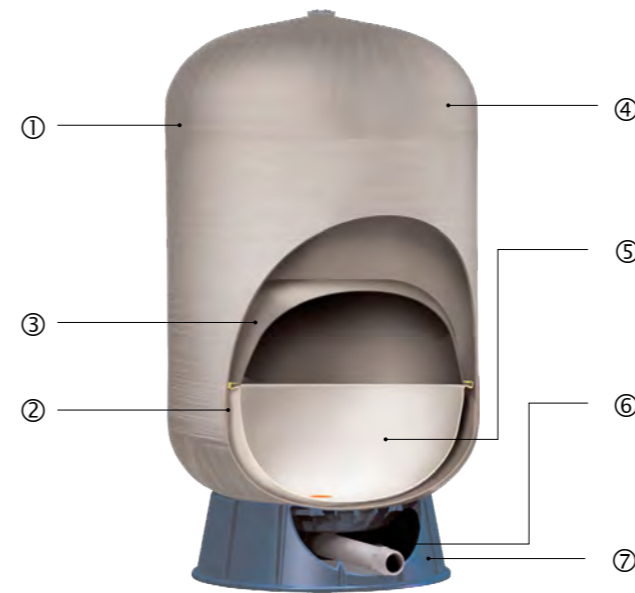

- ① Precision injection molded domes
- ② High-tech spin welding process
- ③ Patented CAD-2 controlled action diaphragm design
- ④ Durable continuous strand fiberglass sealed with epoxy resin
- ⑤ Virgin Polypropylene Liner
- ⑥ Reinforced Plastic Connection
- ⑦ Rugged base

ISO:9001 CE ACS Approved



FlowThru™ SERIES



SPECIFICATIONS FlowThru™ Series Models

BSP	NPT	Nominal Volume		Shipping (box) Volume		Shipping (box) Weight		Dimensions			
		liter	gal	m ³	ft ³	kg	lbs	A		B	
								cm	inches	cm	inches
GFU-80LV	GFU-80LV	80	20	0.13	4.74	15.21	33.5	73.66	29.30	40.69	16.02
GFU-170LV	GFU-170LV	170	45	0.29	10.14	30.90	68.0	92.07	36.25	53.42	21.03
GFU-325LV	GFU-325LV	325	85	0.54	18.93	55.50	122.0	113.03	44.50	66.07	26.01
CFB-60LV	CFN-15GV	60	15	0.13	4.44	8.60	19.0	64.00	25.60	42.16	16.60
CFB-80LV	CFN-20GV	80	20	0.16	5.53	10.90	24.0	86.51	34.06	42.16	16.60
CFB-150LV	CFN-40GV	150	40	0.32	11.45	15.90	35.0	77.44	30.49	61.72	24.30
CFB-200LV	CFN-50GV	200	50	0.34	11.95	20.20	44.5	109.98	43.30	54.61	21.50

System Connection: 1 1/4" BSP / NPT
 Max. Working Pressure 8.6 bar / 125 psi
 Max. Working Temperature 90°C / 194°F (steel) ; 49°C / 120°F (composite)
 Please refer to tank packaging for correct factory set pre-charge information.

* Minor dimensional variation may occur

FEATURES

- Patented Flow-Thru Technology for freshest water
- Available in Composite and Steel
- Patented CAD-2 diaphragm technology
- No stagnation
- Patented Watervane, total recirculation of the water
- Leak free air valve cap sealed with closed cell foam
- Comprehensive testing
- No maintenance

Global Water Solutions now guarantees the freshest water quality possible with the revolutionary Flow-Thru™ Series design, available in both composite and steel models. All Flow-Thru™ tanks feature GWS's exclusive patented Flow-Thru™ technology which assures that your system will provide the freshest water quality possible by simply eliminating stagnation!

The Flow-Thru™ connection diverts system water into, and more importantly out of the tank while the pump is running. This constant flushing action assures that the water in the tank remains as fresh as possible and eliminates the possibility of stagnant water during normal system operation.

Both our steel and composite Flow-Thru™ tanks incorporate our proven patented controlled action diaphragm (CAD-2). CAD-2's steel clench ring regulates movement and prevents the diaphragm from rubbing against the tank wall.

Flow-Thru™ is also the ideal solution for constant pressure water system installers seeking to store water without the risk of stagnation.

Flow-Thru™ tanks are quality tested at several stages on the production line to insure the structural integrity of every tank. Flow-Thru™ tanks represent the best value for the investment and are the best quality Flow-Thru™ vessels available today.

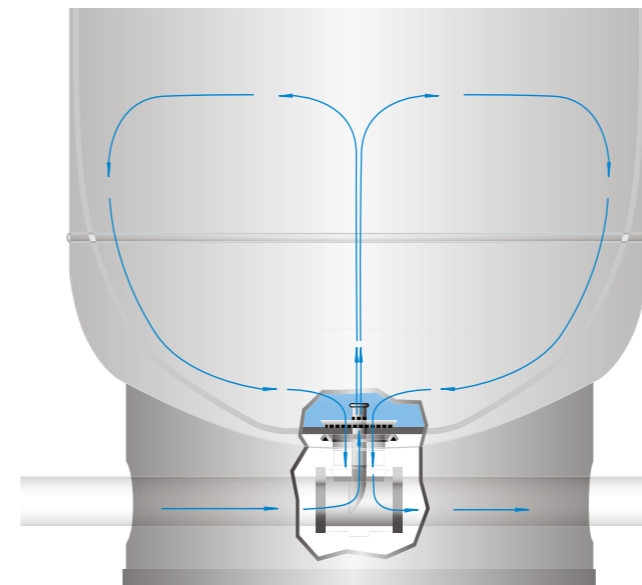

Flow-Thru™ technology assures total recirculation of the tank's water content.

Patented watervane flushes water through the tank eliminating the possibility of stagnant water.

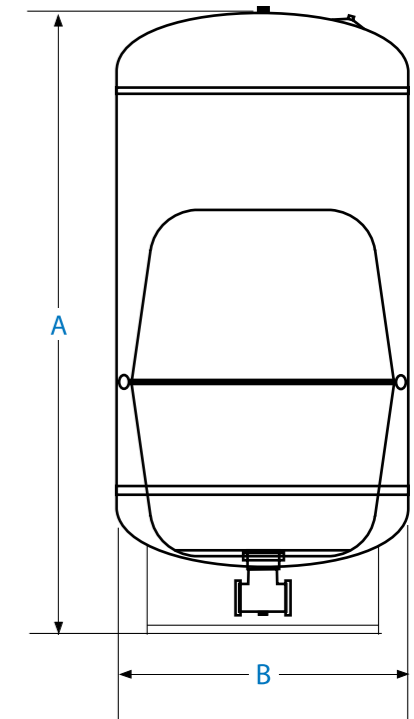

ISO:9001 CE ACS Approved



SuperFlow™ SERIES



FEATURES

- 8 to 10,000 liters for sizes not covered by PressureWave™ and Challenger™ Series
- 10, 16 and 25 bar pressure rating
- Almond RAL 1013
- Built-in pressure gauge (Models SF100-SF10,000)
- ISO : 9001, CE approved

The SuperFlow™ Series

Global Water Solutions' SuperFlow™ tanks are ideally suited for applications where high-pressure ratings are required. These applications include booster systems, heating expansion and hammer arresting in high-rise and multistory buildings such as hotels, hospitals or business centres.

SuperFlow™ tanks range from 8 to 10,000 litres and are available in 10, 16 and 25 bar pressure ratings which makes GWS one of the most comprehensive suppliers globally. The interchangeable membrane design of the tanks allows you to replace the membrane whenever required, and the built-in pressure gauge, starting at tanks of 100 litres size, makes the system-pressure control as easy as possible.

SuperFlow™ Series vessels are quality checked at several stages during the production and given regular maintenance, we recommend pre-charge check every 3 month, these vessels represent the best value for the investment and are designed to serve your needs for years to come.

SPECIFICATIONS SuperFlow™ Series Models

Model Numbers			Connection	Nominal Volume	Ship Weight			Dimensions	
Inline 10 bar	Inline 16 bar	Inline 25 bar			10 bar	16 bar	25 bar	A	B
N/A*	N/A*	SF1225	1"	12	N/A	N/A	9	22	38
N/A*	N/A*	SF1925	1"	19	N/A	N/A	11	28	43
N/A*	N/A*	SF3525	1"	35	N/A	N/A	22	38	47
Vertical 10 bar	Vertical 16 bar	Vertical 25 bar	inches	liters	kg	kg	kg	cm	cm
N/A*	N/A*	SF5025V	1"	50	N/A	N/A	30	38	75
N/A*	N/A*	SF6025V	1"	60	N/A	N/A	33	38	81
N/A*	SF8016V	SF8025V	1"	80	N/A	26	46	43	96
N/A*	SF10016V	SF10025V	1"	100	N/A	28	51	46	99
N/A*	SF15016V	SF15025V	1"	150	N/A	50	85	50	110
N/A*	SF20016V	SF20025V	1 1/4"	200	N/A	68	112	59	112
N/A*	SF30016V	SF30025V	1 1/4"	300	N/A	79	130	64	123
N/A*	SF50016V	SF50025V	1 1/4"	500	N/A	115	202	75	155
SF75010V	SF75016V	SF75025V	2"	750	110	220	328	75	195
SF85010V	SF85016V	SF85025V	2"	850	145	235	344	80	195
SF100010V	SF100016V	SF100025V	2"	1000	165	250	368	80	218
SF150010V	SF150016V	SF150025V	2"	1500	250	375	495	96	238
SF200010V	SF200016V	SF200025V	2"	2000	370	520	745	110	252
SF300010V	SF300016V	SF300025V	2 1/2"	3000	550	780	910	120	280
SF400010V	SF400016V	SF400025V	3"	4000	730	980	1290	145	310
SF500010V	SF500016V	SF500025V	3"	5000	840	1140	1472	145	372
SF1000010V	SF1000016V	SF1000025V	4"	10000	1920	2500	2980	160	575
Horizontal 10 bar	Horizontal 16 bar	Horizontal 25 bar	inches	liters	kg	kg	kg	cm	cm
N/A*	N/A*	SF2425H	1"	24	N/A	N/A	13.5	47	28
N/A*	N/A*	SF5025H	1"	50	N/A	N/A	30	62	38
N/A*	N/A*	SF6025H	1"	60	N/A	N/A	33	67	38
N/A*	SF8016H	SF8025H	1"	80	N/A	26	46	72	43
N/A*	SF10016H	SF10025H	1"	100	N/A	28	51	80	46

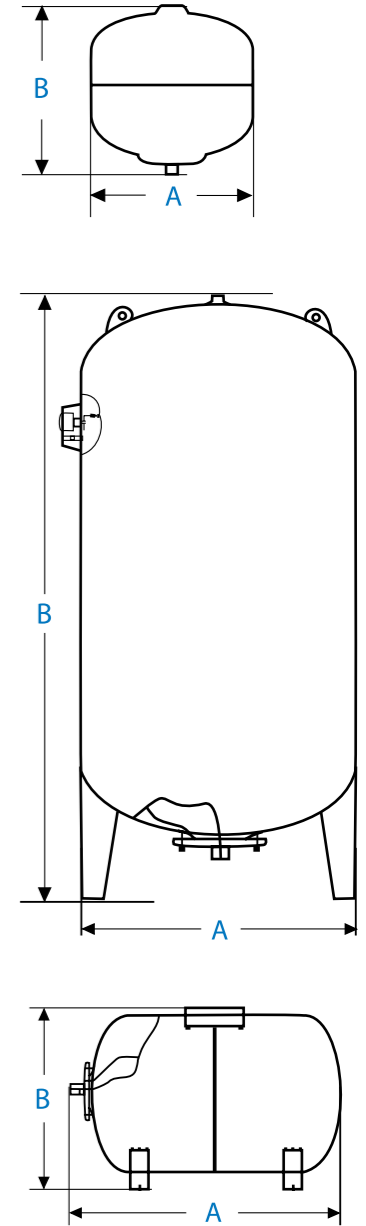

* Minor dimensional variation may occur

Interchangeable membranes

EPDM for SF12-SF2000, Butyl for SF3000 - SF10000, working temperature -5°C / 23°F to 90°C / 194°F
 Tank precharge: 4.0 bar / 58 psi

*Use PressureWave™, Max™ or UltraMax™ Series tanks ** Use Challenger™ Series tanks

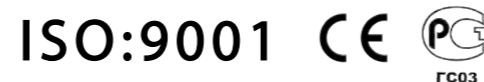

ThermoWave™ SERIES



FEATURES

- High grade butyl diaphragm
- Virgin polypropylene liner
- Two part polyurethane, epoxy primed paint finish
- Patented stainless steel water connection
- Leak free, o-ring sealed air valve cap
- Comprehensive testing
- Maintenance free

ThermoWave™ expansion tanks are specially designed for use in potable water heating applications.

Many homes and buildings have potable water heating systems to provide hot water for washing, cooking, showering, etc. As the water is heated it also expands. This expansion leads to increased system pressure and can cause serious damage. In most systems a relief valve is installed to vent the expanded water volume and prevent the system from exceeding maximum operating pressure. Unfortunately this creates wasted energy as hot water is vented and additional water must be filled and heated again. In order to safely accommodate the natural expansion of water without venting from a relief valve, a ThermoWave™ expansion tank is used. ThermoWave™ expansion tanks conserve water and energy while safely maintaining system operating pressures. They do so by temporarily absorbing the expanded water volume instead of allowing it to be vented out of a relief valve. And because ThermoWave™ expansion tanks use water chambers constructed from high grade Chlorobutyl diaphragms and virgin polypropylene liners they ensure your potable water remains clean and safe.

ThermoWave™ expansion tanks are quality tested at several stages on the production line to ensure the structural integrity of every tank.

ThermoWave™ expansion tanks represent the best value for the investment and are the best quality expansion tanks available today.

SPECIFICATIONS

ThermoWave™ Series Models

Model Numbers	Nominal Volume		Shipping (box) Volume		Shipping (box) Weight		Dimensions					
	liter	gal	m ³	ft ³	kg	lbs	A		B		C	
							cm	inches	cm	inches	cm	inches
TWB-2LX*	2	0.5	0.055	1.94	13.38	29.5	20.6	8.1	12.6	5.0		
TWB-4LX	4	1.1	0.0075	0.26	1.60	3.53	25.80	10.16	16.20	6.40		
TWB-8LX	8	2.1	0.014	0.49	2.20	4.85	31.00	12.20	20.20	7.95		
TWB-12LX	12	3.2	0.023	0.81	2.90	6.39	36.20	14.25	23.00	9.06		
TWB-18LX	18	4.8	0.029	1.02	3.84	8.47	36.40	14.33	27.90	11.20		
TWB-24LX	24	6	0.042	1.48	4.90	10.80	44.40	17.48	29.00	11.42		
TWB-35LX	35	9.2	0.058	2.05	6.70	14.77	47.80	18.90	31.80	12.52		
TWB-20LH	20	5.3	0.042	1.48	5.20	11.46	44.70	17.60	27.90	10.98	14.70	5.79
TWB-24LH	24	6	0.047	1.66	5.90	13.01	44.70	17.60	30.60	12.05	16.10	6.40
TWB-35LH	35	9.2	0.058	2.05	6.90	15.21	48.10	18.90	33.80	13.31	17.90	7.05
TWB-60LH	60	14	0.08	2.83	11.50	25.35	53.00	20.87	40.90	16.10	21.50	8.46
TWB-60LV	60	14	0.08	2.83	10.80	23.81	62.00	24.41	38.90	15.31	12.70	5.00

System Connection: 3/4" BSP
 Maximum Working Pressure: 10 bar / 150 psi
 Factory pre-charge: 1.9 bar / 28 psi
 Maximum Working Temperature: 90°C / 194°F
 * TWB-2LX: 12 pcs/ box

* Minor dimensional variation may occur

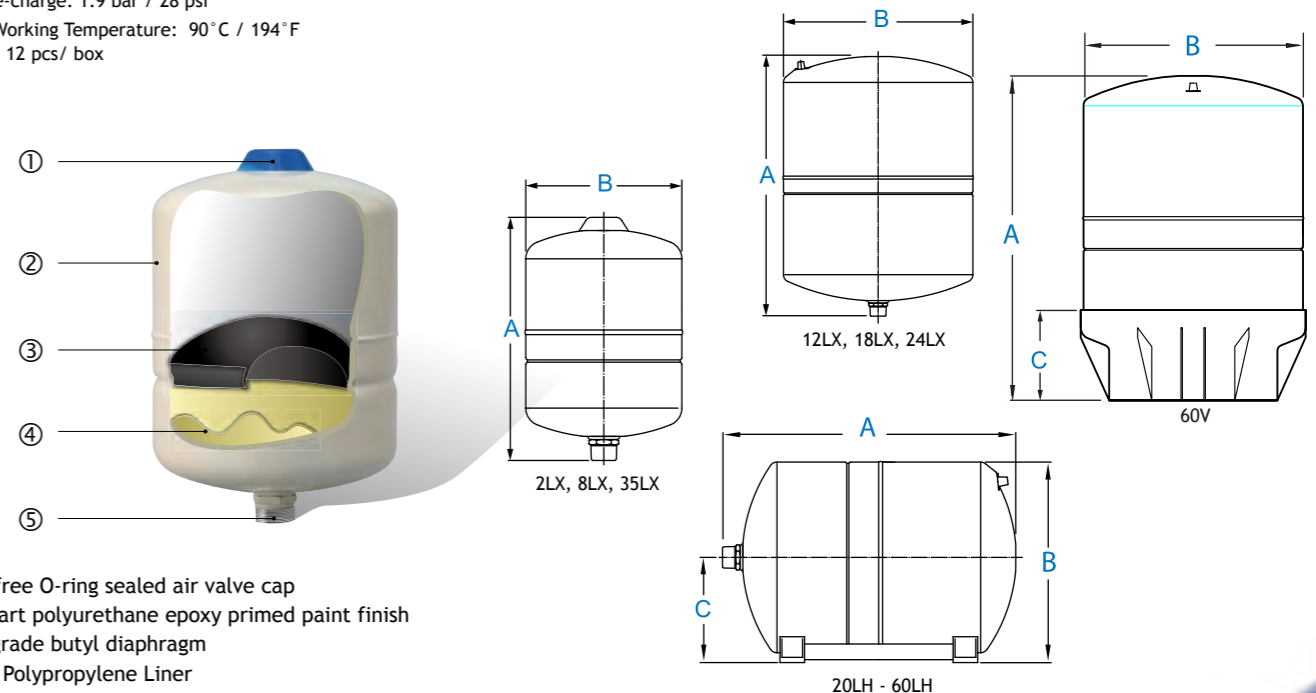

- ① Leak-free O-ring sealed air valve cap
- ② Two-part polyurethane epoxy primed paint finish
- ③ High grade butyl diaphragm
- ④ Virgin Polypropylene Liner
- ⑤ Patented stainless steel water connection

ISO:9001 CE ACS Approved



HeatWave™ SERIES



SPECIFICATIONS HeatWave™ Series Models

Model Numbers	Nominal Volume		Shipping (box) Volume		Shipping (box) Weight		Dimensions					
	liter	gal	m ³	ft ³	kg	lbs	A		B		C	
							cm	inches	cm	inches	cm	inches
HWB-2LX*	2	0.5	0.055	1.94	12.83	28.29	20.90	8.23	12.60	4.96		
HWB-8LX	8	2.1	0.016	0.57	2.20	4.85	31.30	12.32	20.20	7.95		
HWB-12LX	12	3.2	0.023	0.81	2.90	6.39	36.70	14.45	23.00	9.06		
HWB-18LX	18	4.8	0.029	1.02	3.80	8.38	36.70	14.45	27.90	11.20		
HWB-24LX	24	6	0.042	1.48	4.90	10.80	44.70	17.60	29.00	11.42		
HWB-35LX	35	9.2	0.058	2.05	6.70	14.77	48.10	18.94	31.80	12.50		
HWB-60LV	60	14	0.102	3.60	10.80	23.81	57.60	22.68	38.90	15.31	16.00	6.30
HWB-80LV	80	20	0.134	4.73	15.30	33.73	77.10	30.35	38.90	15.31	16.00	6.30
HWB-100LV	100	26.4	0.168	5.93	18.20	40.12	80.40	31.65	43.00	16.90	12.90	5.08
HWB-130LV	130	34.3	0.21	7.41	26.70	58.86	107.40	42.28	43.00	16.90	12.90	5.08
HWB-150LV	150	40	0.28	9.89	31.40	69.23	92.40	36.38	53.00	20.87	13.85	5.45

Factory pre-charge: HWB-2LX - HWB-24LX 0.7 bar / 10 psi ; HWB-35LX 1 bar / 15 psi ; HWB-60LV-HWB-150LV 1.5 bar / 22 psi * Minor dimensional variation may occur
 Maximum Working Temperature: 99°C / 210°F
 Maximum working pressure 6 bar / 87 psi
 System Connection: HWB-2LX - HWB-80LV chromed carbon steel 3/4" BSP inline ; HWB-100LV - HWB-150LV stainless steel 1" BSP Elbow*
 HWB-2LX: 12 pcs / box

FEATURES

- High grade butyl diaphragm
- Two part polyurethane, epoxy primed paint finish
- Leak free, o-ring sealed air valve cap
- Comprehensive testing
- ISO:9001, GOST, CE/PED approved

HeatWave™ tanks are the quality solution for hydronic expansion. HeatWave™ tanks are built to the same stringent standards as the PressureWave™ and Challenger™ tanks.

With an incorporated hex nut system connection, HeatWave™ tanks are easy to install. Its air chamber sealed with a brass air valve and o-ring sealed air cap will provide many years of leak free and service free life. Its two part polyurethane, epoxy primed paint finish will withstand the harshest indoor and outdoor climates throughout the world. HeatWave™ tanks are quality tested at several stages on the production line to insure the structural integrity of every tank.

The HeatWave™ expansion tank is designed to be either supported by the system piping, the wall mounting bracket (inline models) or freestanding (vertical models w/ base).

The expansion tank, pipes and your connections if installed incorrectly could leak water. Install the expansion tank in a location where any water leak will not cause damage. The manufacturer is not responsible for any water damage in connection with this expansion tank.

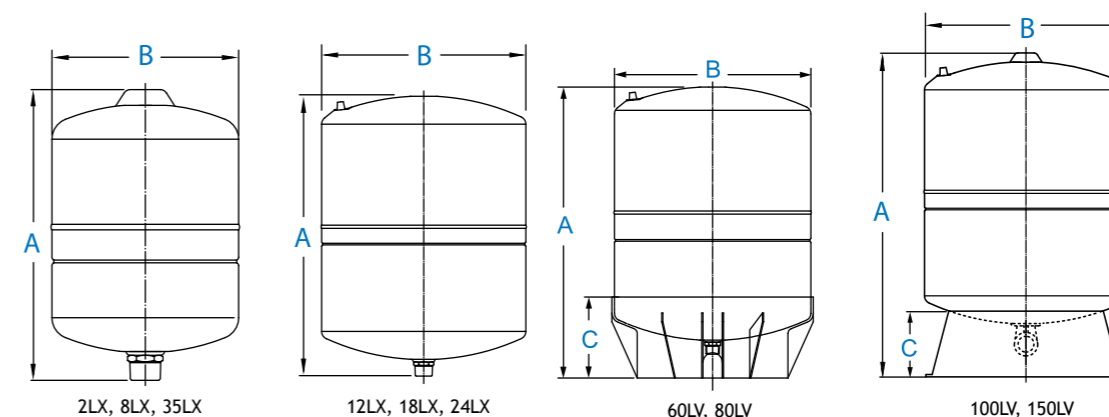

SolarWave™ SERIES



FEATURES

- High temperature butyl diaphragm
- High expansion volume factor
- Two part polyurethane, epoxy primed paint finish
- Leak free o-ring sealed air valve cap
- Comprehensive testing
- No maintenance

If you are looking for the proven performance of a GWS tank, SolarWave™ expansion tanks are the quality solution for your solar system. SolarWave™ expansion tanks are designed to control the expansion and contraction of solar thermal transfer fluids in solar heating systems. The SolarWave™ Series is intended for use on the solar liquid loop of indirect thermal transfer systems.

SolarWave™ tanks are built to the same stringent standards as PressureWave™ and Challenger™ tanks. They meet the demands of solar collector systems for both thermal expansion and contraction in order to maintain safe and efficient operating pressures within the solar liquid system.

A properly sized SolarWave™ tank will eliminate the need for recharging the system after periods of no use or in cases of extreme temperature buildup. It will eliminate relief valve release of system liquid and maintain minimum operating pressures throughout the system.

SolarWave™ Series expansion tanks have a large acceptance volume making them ideal for expansion and contraction control of solar collector systems which operate under a wide range of pressure and temperature.

SolarWave™ tanks are quality tested at several stages on the production line to insure the structural integrity of every tank. SolarWave™ tanks represent the best value for the investment and are the best quality solar expansion vessels available today.

SPECIFICATIONS SolarWave™ Series Models

Model Numbers	Nominal Volume		Shipping (box) Volume		Shipping (box) Weight		Dimensions					
	liter	gal	m ³	ft ³	kg	lbs	A		B		C	
							cm	inches	cm	inches	cm	inches
SWB-2LX*	2	0.53	0.055	1.94	13.38	29.5	20.90	8.23	12.60	4.96		
SWB-8LX	8	2.1	0.016	0.57	2.20	4.85	31.30	12.32	20.20	7.95		
SWB-12LX	12	3.2	0.023	0.81	2.90	6.39	36.40	14.33	23.00	9.06		
SWB-18LX	18	4.8	0.029	1.02	3.80	8.38	36.70	14.45	27.90	10.98		
SWB-24LX	24	6	0.042	1.48	4.90	10.80	44.70	17.60	29.00	11.42		
SWB-35LX	35	9.2	0.058	2.05	6.70	14.77	48.10	18.94	31.80	12.50		
SWB-60LV	60	14	0.102	3.60	10.80	23.81	57.60	22.68	38.90	15.31	16.00	6.30
SWB-80LV	80	20	0.134	4.73	15.30	33.73	77.10	30.35	38.90	15.31	16.00	6.30
SWB-100LV	100	26.4	0.168	5.93	18.20	40.12	80.40	31.65	43.00	16.90	12.90	5.08
SWB-130LV	130	34.3	0.21	7.41	26.78	59.04	107.40	42.28	43.00	16.90	12.90	5.08
SWB-150LV	150	40	0.21	7.41	26.78	59.04	107.40	42.28	43.00	16.90	12.90	5.08

Maximum system temperature: 130°C / 266°F

Maximum working pressure: 10 bar / 150 psi

System connection: SWB-2LX - SWB-80LV chromed carbon steel 3/4" BSP inline ; SWB-100LV - SWB-150LV stainless steel 1" BSP Elbow

Factory pre-charge: 1.9 bar / 28 psi

* PWB-2LX and PWN-2LX: 12 pcs/ box

* Minor dimensional variation may occur

Above 150 liter use Challenger™ Series tanks

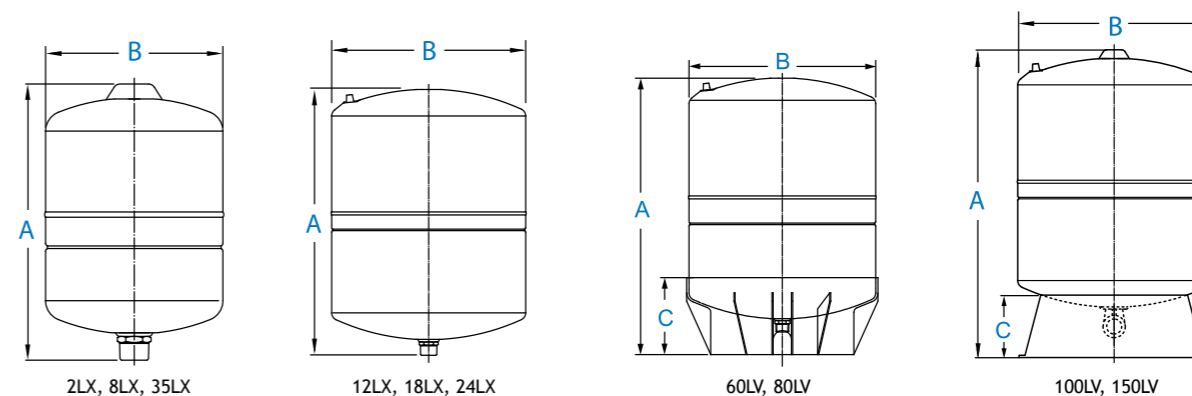

If the temperature of the solar system has the potential to rise above the evaporation point of the solar liquid a condenser chamber or coil is required between the solar collector and SolarWave™ Series expansion tank in order to control the maximum fluid temperature at the SolarWave™ tank.

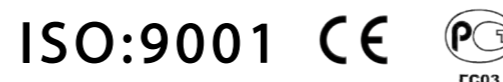

PumpWave™ SERIES



FEATURES

- Starting pressure adjustable from 1 to 2.5 bar
- LED Indicators: Power On, Pump On/Pump Off, Dry Run Control, Reset
- Relay for direct command of motor up to 1.5 kW 220 V AC 50/60 Hz

The PumpWave™ Series is an electronic autoclave pump control, which eliminates frequent small drawoff pump starts due to leaks and low flow pumping applications. PumpWave™ combines an internal water reservoir with an electronic control that allows for complete automatic management of most electric pumps. The process is simple. PumpWave™ draws water from the internal water reservoir until the adjustable START pressure is reached, then PumpWave™ switches the electronic pump on and allows it to run until there is no longer any flow within the system. PumpWave™ assures a constant flow and provides guaranteed protection against pump dry run. PumpWave™ simplifies pump installation as it doubles as a sturdy pump stand suitable for most electric pumps, saving space and assembly time.

PumpWave™ threads directly onto the 1" water connection of any GWS horizontal tank for full pump control with the right pressure tank.

Model	Weight (kg)	Max. Pressure (bar)	Connection	Dimensions	
				Height	Width
PUW Electronic	2.0	10	1" GAS	22 cm	15 cm

The PumpWave™ can also be purchased together with the PressureWave Series Horizontal tanks.

- PumpWave™ electronic is suitable for single-phase motors up to 1.5 kW
- Factory START pressure at 1.8 bar
- PumpWave™ must be installed with an electric pump with a minimum operating pressure of at least 1 bar above the programmed START pressure
- Maximum Capacity: 100 L/min

Accessories



3 Way Connector
A3WYC-BSP
 3 Way Brass Connector 1" MFF BSP
A3WYC-NPT
 3 Way Brass Connector 1" MFF NPT



5 Way Connector
A5WYC-BSP
 5 Way Brass Connector 1" MFF BSP
 1/4" MF
A5WYC-NPT
 5 Way Brass Connector 1" MFF NPT
 1/4" MF



Smart Pressure Valve
ASP1
 Smart Pressure Valve with check valve 1" NPT
ASP2
 Smart Pressure Valve without check valve 1" NPT



Pressure Switches
APSW2F
 Pressure Switch with 1/4" Female Connection 1.4-2.8 bar (20/40 psi)
APSW3F
 Pressure Switch with 1/4" Female Connection 2.1-3.4 bar (30/50 psi)



Stainless Steel Flex Connector
A70MFC-BSP
 700mm M/F SS Flex Connector 1" BSP
A70MFC-NPT
 700mm M/F SS Flex Connector 1" NPT
A80MFC-BSP
 800mm M/F SS Flex Connector 1" BSP
A80MFC-NPT
 800mm M/F SS Flex Connector 1" NPT
A100MFC-BSP
 1000mm M/F SS Flex Connector 1" BSP
A100MFC-NPT
 1000mm M/F SS Flex Connector 1" NPT



Stainless Steel Flex Connector w/ Elbow
A70MFEC-BSP
 700mm M/F SS Flex Elbow Connector 1" BSP
A70MFEC-NPT
 700mm M/F SS Flex Elbow Connector 1" NPT
A80MFEC-BSP
 800mm M/F SS Flex Elbow Connector 1" BSP
A80MFEC-NPT
 800mm M/F SS Flex Elbow Connector 1" NPT
A100MFEC-BSP
 1000mm M/F SS Flex Elbow Connector 1" BSP
A100MFEC-NPT
 1000mm M/F SS Flex Elbow Connector 1" NPT



Pressure Gauges
A2PG
 2" Pressure Gauge 0-7 bar (100 psi) 1/4" male
A25PG
 2.5" Pressure Gauge 0-10 bar (145 psi) 1/4" male



Universal Bracket
BR UNIVERSAL
 Stainless belt with mounting bracket.

